

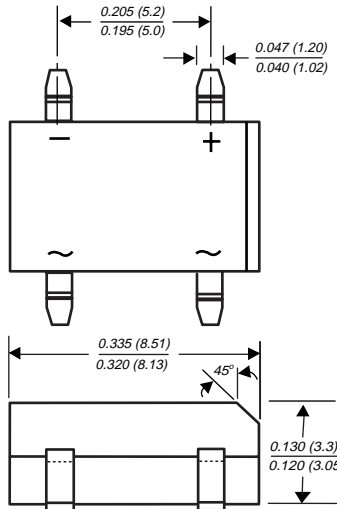

## Miniature Glass Passivated Single-Phase Surface Mount Bridge Rectifiers

Reverse Voltage 50 to 1000V  
Forward Current 1.5A

Case Style DFS



Dimensions in inches and (millimeters)

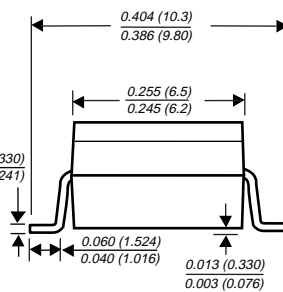

Mounting Pad Layout

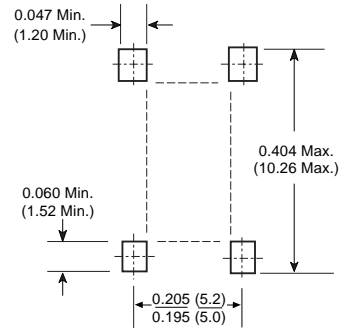

### Mechanical Data

**Case:** Molded plastic body over passivated junctions

**Terminals:** Plated leads solderable per MIL-STD-750, Method 2026

High temperature soldering guaranteed:  
260°C/10 seconds at 5 lbs. (2.3kg) tension

**Polarity:** Polarity symbols marked on body

**Mounting Position:** Any **Weight:** 0.014 oz., 0.4 g

**Packaging codes/options:**

27/1.5K per 13" Reel (16mm Tape)

45/50 ea. per Tube-Bulk

### Features

- Plastic package has Underwriters Laboratory Flammability Classification 94V-0
- This series is UL listed under Recognized Component Index, file number E54214
- Glass passivated chip junctions
- High surge overload rating of 50 Amperes peak
- Ideal for printed circuit boards

### Maximum Ratings and Thermal Characteristics (T<sub>A</sub> = 25°C unless otherwise noted)

Parameter	Symbol	DF15005S	DF1501S	DF1502S	DF1504S	DF1506S	DF1508S	DF1510S	Unit
Maximum repetitive peak reverse voltage	V <sub>RRM</sub>	50	100	200	400	600	800	1000	V
Maximum RMS voltage	V <sub>RMS</sub>	35	70	140	280	420	560	700	V
Maximum DC blocking voltage	V <sub>DC</sub>	50	100	200	400	600	800	1000	V
Maximum average forward output rectified current at T <sub>A</sub> = 40°C <sup>(2)</sup>	I <sub>F(AV)</sub>	1.5							A
Peak forward surge current single half sine-wave superimposed on rated load (JEDEC Method) T <sub>J</sub> = 150°C	I <sub>FSM</sub>	50							A
Rating for fusing (t < 8.3ms)	I <sup>2</sup> t	10							A <sup>2</sup> sec
Typical thermal resistance per leg <sup>(2)</sup>	R <sub>θJA</sub> R <sub>θJL</sub>	40 15							°C/W
Operating junction and storage temperature range	T <sub>J</sub> , T <sub>STG</sub>	-55 to +150							°C

### Electrical Characteristics (T<sub>A</sub> = 25°C unless otherwise noted)

Max. instantaneous forward voltage drop per leg at 1.5A	V <sub>F</sub>	1.1	V
Maximum DC reverse current at rated DC blocking voltage per leg	I <sub>R</sub>	5.0 500	μA
Typical junction capacitance per leg <sup>(1)</sup>	C <sub>J</sub>	25	pF

**Notes:** (1) Measured at 1.0 MHz and applied reverse voltage of 4.0 Volts

(2) Units mounted on P.C.B. with 0.51 x 0.51" (13 x 13mm) copper pads

Vishay Semiconductors  
formerly General Semiconductor

## Ratings and Characteristic Curves ( $T_A = 25^\circ\text{C}$ unless otherwise noted)

**Fig. 1 - Derating Curve Output Rectified Current**

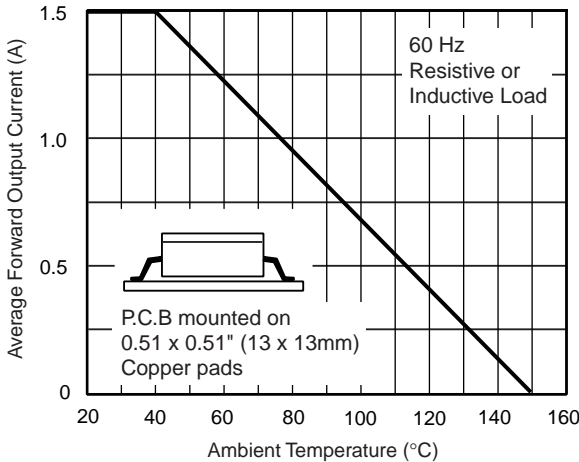

**Fig. 2 - Maximum Non-Repetitive Peak Forward Surge Current Per Leg**

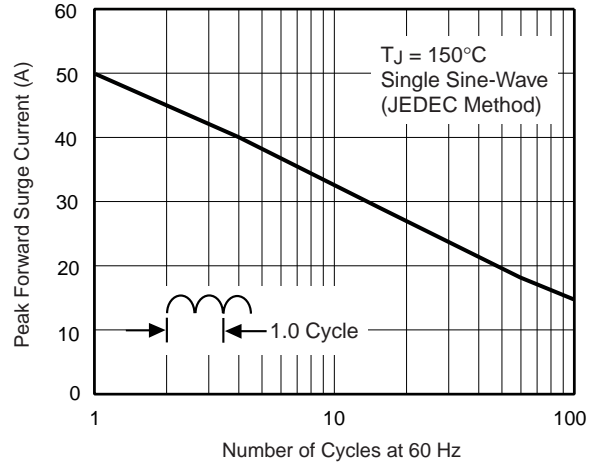

**Fig. 3 - Typical Forward Characteristics Per Leg**

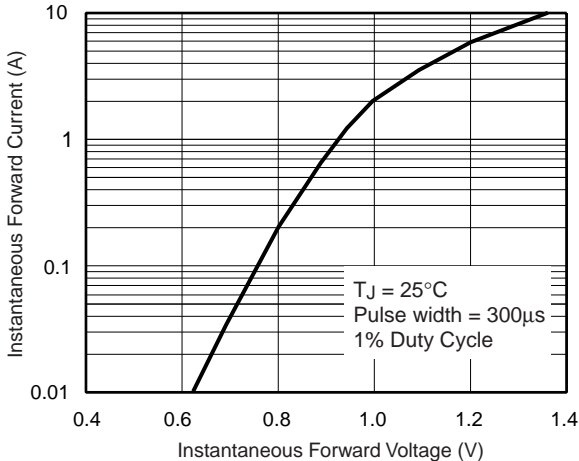

**Fig. 4 - Typical Reverse Leakage Characteristics Per Leg**

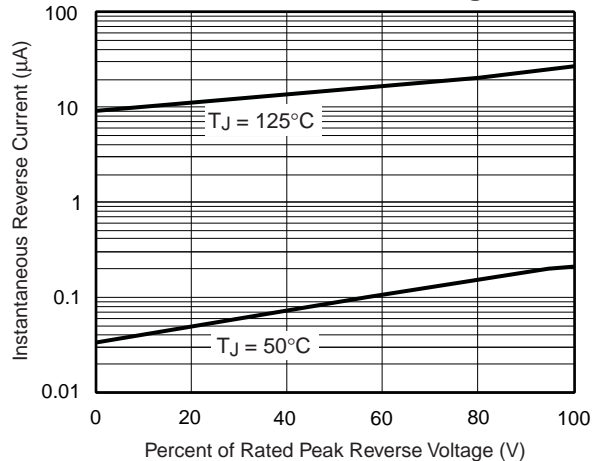

**Fig. 5 - Typical Junction Capacitance Per Leg**

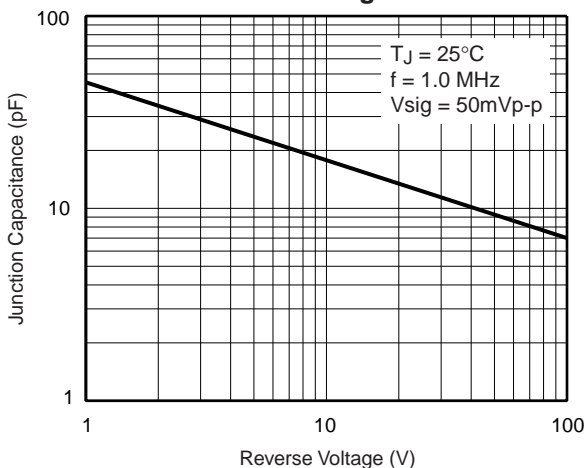

**Fig. 6 - Typical Transient Thermal Impedance**

